



INSTALLATION INSTRUCTIONS

TRACKER/SIDEKICK 1994 & EARLIER

PART #884-030

KAYLINE MFG.

Thank you for purchasing Kayline's Convertible Top for your Jeep® vehicle. It has been designed for great fit and long wear. Please read and follow, precisely, all installation instructions provided when installing top. Failure to do so may result in a poor fitting top and could place occupants in a potentially hazardous situation.

INSTALLATION TIPS

Before you begin installing this top, here are a few tips to make installation easier.

This top should be installed where the temperature is above 72 degrees Fahrenheit. Below this temperature, the top may contract making it difficult to install.

It is normal for a top to contract and wrinkle when stored in the shipping carton. The top will relax and wrinkles will disappear within a few days of installation as fabric adjusts to shape of mounting hardware.

INSTALLATION PROCEDURES:

Step 1. Remove original soft top. Remove original tailgate retainer from rear curtain of old soft top. It will be used with your new top.

Step 2. Pivot windshield arm to the rear so that it rests on targa bar. The underside should now be facing upwards. See figure 1.

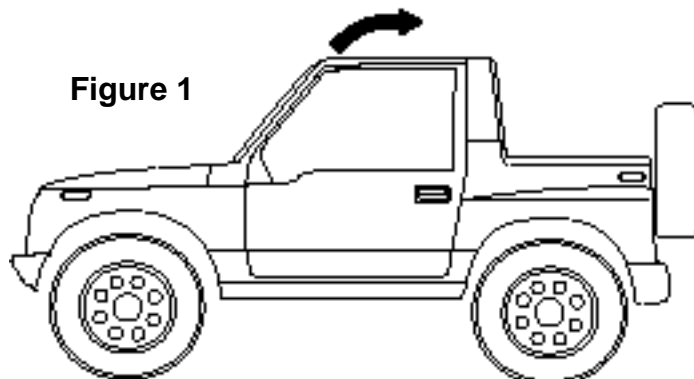
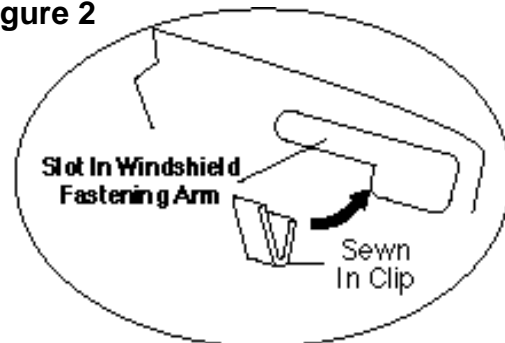

Figure 1

Step 3. Attach sewn in clips into slots in windshield fastening arm. See figure 2. Insert plastic corner clips into position at rear corner of vehicle.

Step 4. Wrap side panels around side panel braces. Fasten hook and loop together. Snap side panel braces into their respective clips. Zip rear curtain into place. Place original tailgate retainer into bottom of rear curtain and clip to tailgate. Pull windshield fastening arm forward and lock into place at windshield frame.

Figure 2



CARE INSTRUCTIONS

Convertible tops and accessories require special care if you want to get the maximum usage and enjoyment from them. The following recommendations, if followed carefully, can extend the life of your top or accessory.

- 1. Hand wash using a mild non-detergent soap such as Ivory. Use a nonabrasive cloth or sponge. Rinse thoroughly.*
- 2. **DO NOT** wash in direct sunlight and avoid automatic car washes.*
- 3. When your top is clean, we recommend using "303 Protectant" on both the vinyl top and windows. This product contains a sunscreen that helps protect from the sun's damaging rays. Stay away from products containing alcohol as it will cause the fabric and windows to lose their elasticity, thus reducing the life of your top or accessory. If you are unable to locate "303 Protectant", please call 1-800-223-4303 for a distributor near you.*
- 4. Direct sunlight and heat are the biggest enemies of the windows. Park in the shade whenever possible. If you must park in the sunlight, rotate the direction that you park every few days so all windows get even exposure.*
- 5. Our tops are designed so that you may roll up and/or store the rear curtain and side curtains. To prevent scratching of the windows, be sure that windows are completely clean and free of dust particles. Even a little dirt will badly scratch the windows. You may want to use a soft cloth when rolling up or storing your windows. Heat may build up on rolled up windows, so be sure to unroll them frequently. If you roll up the windows at the beginning of summer and leave them, they may be ruined by fall.*
- 6. **DO NOT** open or roll up windows at temperatures below 45 degrees F. This could cause them to crack or break.*
- 7. **NEVER** use ice scrapers or snow brushes on vinyl windows.*

WARRANTY INFORMATION:

*Kayline manufacturing warrants to the original purchaser of any product it manufactures, that the product will be free of defects in material or workmanship for a period of 90 days from date of purchase. Such obligations under this warranty shall be limited to the **repair or replacement**, at Kayline's discretion, of any assembly or parts which upon examination by Kayline proves to be defective. All defective items must be returned with proof of purchase to Kayline Manufacturing, 200 East 64th Avenue, Denver, Colorado 80221, freight prepaid. This warranty does not cover damage resulting from abuse, misuse, alteration, accident or damage in transit. Kayline's obligations under this warranty are limited to the aforementioned repair or replacement of warranty defects for which the return authorization has been received during the warranty period, and **KAYLINE SHALL NOT BE LIABLE FOR ANY INCIDENTAL OR CONSEQUENTIAL DAMAGES ARISING FROM BREACH OF THIS OR ANY IMPLIED WARRANTY.***

Some states do not allow the exclusion or limitation of incidental or consequential damages, so the above limitation or exclusion may not apply to you. This warranty gives you specific legal rights, and you may also have other rights which may vary from state to state.

If you need assistance or further information, you may contact Kayline at 1-800-525-8118 between the hours of 8:00 AM and 5:00 PM, Monday through Friday, Mountain Standard Time.