



INSTALLATION INSTRUCTIONS

SCOUT II ROLL BAR TOP

PART #442-050

KAYLINE MFG.

Thank you for purchasing Kayline's Roll Bar Top for your Scout vehicle. It has been designed for great fit and long wear. Please read and follow, precisely, all installation instructions provided when installing top. Failure to do so may result in a poor fitting top and could place occupants in a potentially hazardous situation.

TOOLS REQUIRED:

1/8" DRILL BIT 5/32" DRILL BIT
#2 PHILLIPS SCREWDRIVER

PARTS LIST:

2 ea Footman Loop
4 ea #8 x 1/2 Sheet Metal Screws
3 ea Sheet Metal Screw Studs

INSTALLATION TIPS

Before you begin installing this top, here are a few tips to make installation easier.

This top should be installed where the temperature is above 72 degrees Fahrenheit. Below this temperature, the top may contract making it difficult to install.

It is normal for a top to contract and wrinkle when stored in the shipping carton. The top will relax and wrinkles will disappear within a few days of installation as fabric adjusts to shape of mounting hardware.

INSTALLATION PROCEDURES:

STEP 1. Your vehicle must be equipped with windshield slot and channel for this top to be installed properly. If you have already installed slot and channel disregard this step. If not you will have to order part #442-9440. Position windshield slot on top of windshield frame centered from side to side with the weather stripped edge toward the vertical flange on windshield frame. Place channel under slot. The channel will act as a shim to provide proper clearance between windshield frame and slot. Starting at the center mark and drill 1/8" hole using slot as a template. Secure to windshield frame with #10 x 1/2" sheet metal screw. Drill remaining holes one at a time and installing sheet metal screws as you go, making sure that gap between frame and slot remains constant from side to side. Channel should slide under slot with little resistance. Form ends of slot around windshield frame. See figure 1.

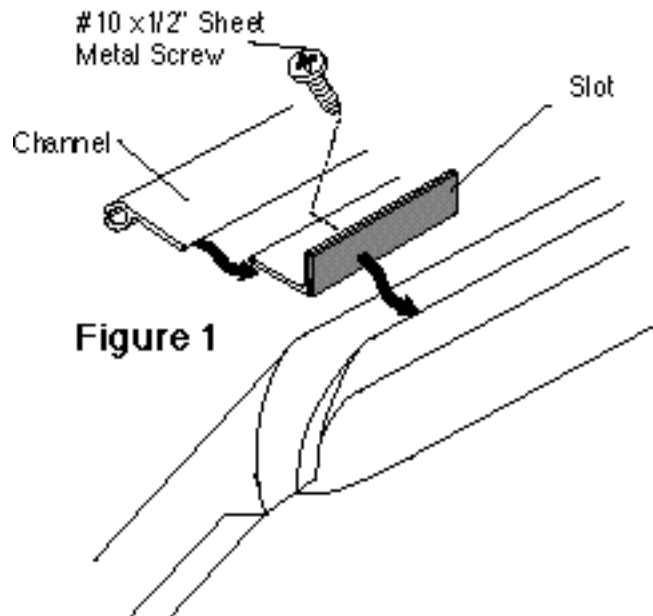

Figure 1

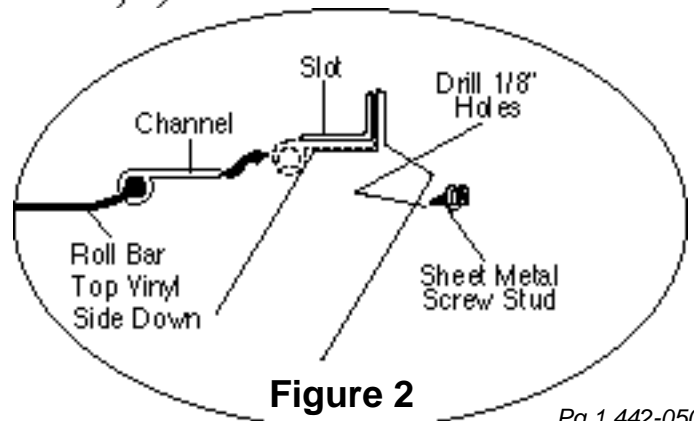
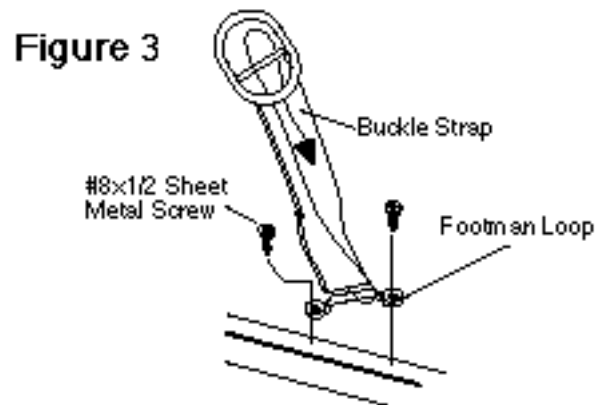

Figure 2

STEP 2. Slide sewn in rope on roll bar top, vinyl side down, into channel. Place channel into gap between slot and windshield frame. Flip top over roll bar. See figure 2.

STEP 3. Pull sewn in buckle straps to the rear of vehicle. Place footman loops on top of body edge to a point where buckle straps can easily be threaded through and still allow enough length to tighten down properly. This point will be approximately over the rear wheel. Mark and drill 1/8" holes using footman loop as a template. Secure to body with #8 x 1/2 sheet metal screws. Thread buckle strap through footman loop and tighten. See figure 3.

STEP 3. Pull forward and down on snaps at front corners of top. Mark and drill 1/8" holes using snaps as a guide. Install sheet metal screws/studs and snap top to studs. See figure 2.



CARE INSTRUCTIONS

Convertible tops require special care if you want to get the maximum usage and enjoyment from them. The following recommendations, if followed carefully, can extend the life of your top.

- 1. Hand wash using a mild non-detergent soap such as Ivory. Use a nonabrasive cloth or sponge. Rinse thoroughly.*
- 2. **DO NOT** wash in direct sunlight and avoid automatic car washes.*
- 3. When your top is clean, we recommend using "303 Protectant" on both the vinyl top and windows. This product contains a sunscreen that helps protect from the sun's damaging rays.*
- 4. When top is not in use store in bag provided.*

WARRANTY INFORMATION

*Kayline manufacturing warrants to the original purchaser of any product it manufactures, that the product will be free of defects in material or workmanship for a period of 90 days from date of purchase. Such obligations under this warranty shall be limited to the **repair or replacement, at Kayline's discretion**, of any assembly or parts which upon examination by Kayline proves to be defective. All defective items must be returned with proof of purchase to Kayline Manufacturing, 200 East 64th Avenue, Denver, Colorado 80221, freight prepaid. This warranty does not cover damage resulting from abuse, misuse, alteration, accident or damage in transit. Kayline's obligations under this warranty are limited to the aforementioned repair or replacement of warranty defects for which the return authorization has been received during the warranty period, and **KAYLINE SHALL NOT BE LIABLE FOR ANY INCIDENTAL OR CONSEQUENTIAL DAMAGES ARISING FROM BREACH OF THIS OR ANY IMPLIED WARRANTY.***

Some states do not allow the exclusion or limitation of incidental or consequential damages, so the above limitation or exclusion may not apply to you. This warranty gives you specific legal rights, and you may also have other rights which may vary from state to state.